

# Wood Carvers

Wood carvers carve, if you want to be a wood carver, carve!

If you want to be a skilled wood carver:

- Keep tools sharp and polished.
- Use stop cuts.
- Slice the wood.
- Carve every day.
- Teach beginners.
- Take classes.
- Attend wood carving events, meetings, shows.
- Teach friends to criticize your work.
- Buy only the best tools.
- Buy only the best wood.
- Use a holding device to hold your carvings.
- Use both hands on the tools.
- Use a mallet.
- Read carving, drawing and sculpture books, magazines, and videos.
- Study your subject; know the correct era of your clothes, hat, buildings, guns, boats, cars, and such.
- Learn observation of every detail we don't see things in detail we see things as a whole. Do you know what a cow's head really looks like? For sure??
- Approach carving as a life-long learning process.
- Be willing to try new things.
- Practice what you learn in class by doing repeated carvings which allow you to apply the techniques taught.
- Look at your work several times over a period of time to judge your readiness to move to the next step.
- Don't rush, take your time.
- Don't get into the details too soon, shape the overall piece.
- Support and encourage your fellow wood carvers and they will reciprocate.
- Find a subject that excites you.
- As you are starting to carve, find something about your carving that you like.
- Carve at your own pace. Do not rush!

# Carving a Doughnut by Larry Nowell

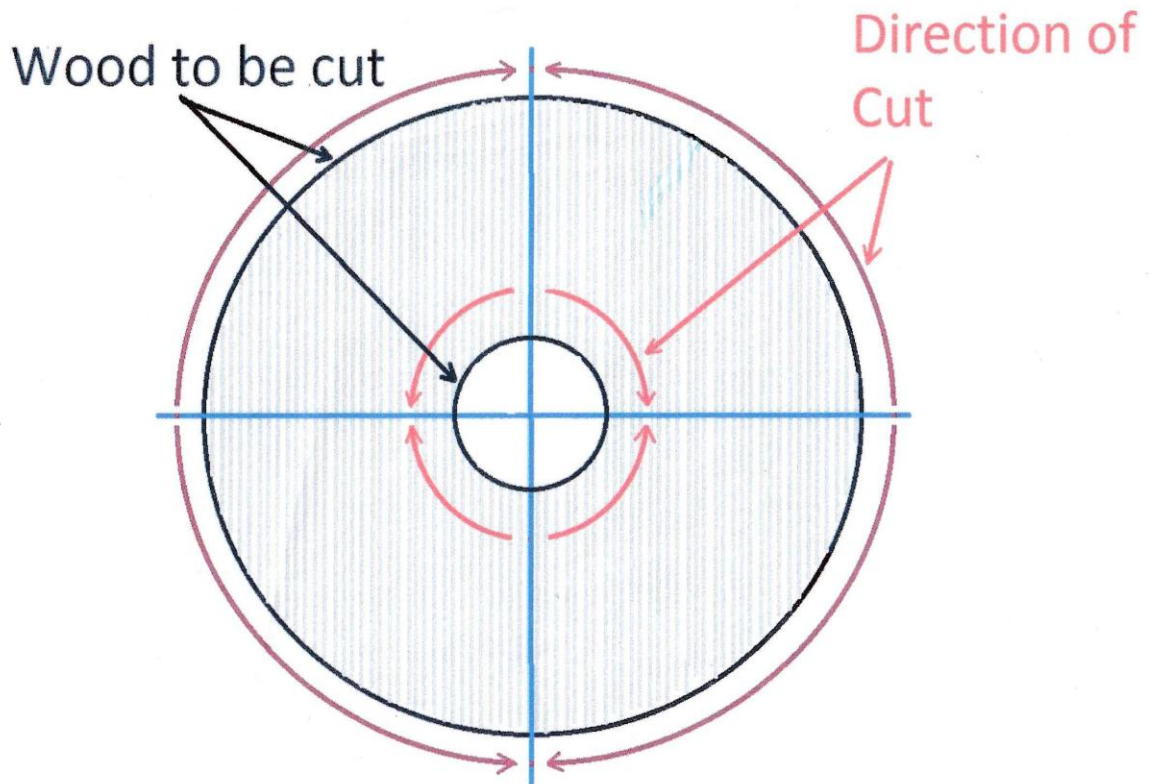

1. Cut from short grain to long grain.
2. Compress fibers back against themselves.